



For your calendar:

PTA Meeting

The next PTA meeting is on Wednesday 21 January 2026 at The Blenheim Pub at 8.00pm.
Everyone is welcome.

Monday 2.2.26 8.50am – 9.50am

Coffee morning for families whose children have a Special Educational Need or Disability (SEND)
All welcome.

Coming up soon:

For assemblies / performances during the school day, exit via the West Gate will only be possible at the end of the performance.

January		
Monday 19.1.26	7.00pm – 8.00pm	How to help your child develop strong foundations in maths – workshop for YN and YR Parents/Carers. Book your space here .
Tuesday 20.1.26	8.45am – 9.45am *this session is now fully booked.	How to help your child develop strong foundations in maths – workshop for YN and YR Parents/Carers. Please note, this workshop will be strictly limited to 35 attendees due to space limitations. Spaces will be allocated in sign up order from the Google sign up sheet.
Tuesday 20.1.26	8.45am – 9.30am	3W's Class Assembly for Parents/Carers and book look in the Hall
Wednesday 21.1.26	8.35am – 9.00am	Second hand uniform shop open via South Gate
Wednesday 21.1.26	8.45am – 9.30am	3L's Class Assembly for Parents/Carers and book look in the Hall
Wednesday 21.1.26	8.00pm	PTA Meeting at The Blenheim pub – All welcome
Thursday 22.1.26	8.45am – 9.30am	3WH's Class Assembly for Parents/Carers and book look in the Hall
Thursday 22.1.26	12.00pm – 11.30pm	Y5 Young Voices visit to O2 Arena
Wednesday 28.1.26	8.45am – 9.30am	5T's Class Assembly for Parents/Carers and book look in the Hall
Thursday 29.1.26	8.45am – 9.30am	5P's Class Assembly for Parents/Carers and book look in the Hall
Friday 30.1.26	8.45am – 9.30am	5J's Class Assembly for Parents/Carers and book look in the Hall

Our Second Hand Uniform Shop will be open on Wednesday 21 January between 8.35am – 9.00am in the Club House. Please enter and exit via the South Gate. All items are priced at £1 each.

Reminders for you

Class Assemblies

We are looking forward to all the Class Assemblies over the next few weeks. Please drop your child off as normal, to go to class. The Hall will open at 8.35am and

Golden Books

Golden Books will be coming home this week, please remember to write a positive message on the sticker and return the books to school for

Missing Library Books

Please could you check at home for any library books that need to be returned.

Thank you.

children's books will be available in the Hall for you to look at before the assembly starts.

safekeeping.



Year 1 Weekly Information w/b 19.1.26

Class Assemblies

Year 1 have now begun practising for their class assembly.

Please help them practise their lines at home – you will find these in their Learning Journals towards the end of the week!

Please note the date of your child's Class Assembly below:

Wednesday 11 February – 1S

Thursday 12 February – 1M

Friday 13 February – 1MV

Library Books

Please help your child to look after their library book.

Once they have enjoyed their library book at home, we ask that it goes back into their bookbag. This ensures they are able to change it over on their library days.

Golden Books

Your child will be bringing home their Golden Book this week.

We hope you enjoy looking through their fantastic work.

Please remember to write a comment on the sticker at the back of the book before returning to school.

Grow your child's sense of [self-efficacy](#)

Sometimes when life is busy, and our child asks us to do something for them or help them with something, we do it without pausing to think about whether they could do it for themselves. If we encourage them to 'have a go' first, it grows their sense of self efficacy making them more independent and more confident in their ability to cope with new things. Sometimes a helpful verbal 'tip' can be all they need. For example:

Child: "Can you open my satsuma for me?"

Help them to 'have a go': "Why don't you have a go? Start by pushing your thumb into the 'dip' on the skin."

Child: "Please can I have a drink?"

Help them to 'have a go': "Yes – help yourself to some water. The cups are in the low cupboard now."

Child: "How do you spell 'birthday'?"

Help them to 'have a go': "I think you can do it yourself. Why don't you use your 'Fred' fingers!" (i.e. encourage them to use the sounds they know, even if the spelling isn't perfect yet, praise the effort)

Talk through Stories

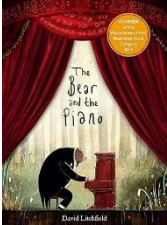
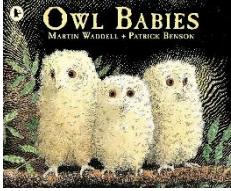
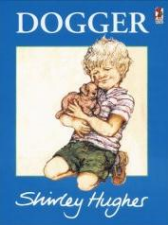
		
1S	1MV	1M

In maths this week, we will begin subtracting within 20. Earlier in the year, children subtracted within 10 by counting back and using number lines. They will now subtract within 20 using their knowledge of number bonds. For example, if they know the number bond $7 - 5 = 2$, then they know that $17 - 5 = 12$. By completing these calculations side by side using ten frames, counters, part-whole models or base 10, children see that the second subtraction will have an answer that is 10 greater than the first subtraction.

This week in Fluency Bee

w/b 19.1.26	Bonds to 9 Subitise 10 (dots) Subitise 10 (objects) Composition of 10 as 5 and 5
----------------	---

What do you see?

What is the missing part?



9 is the whole.
3 is a part.
6 is a part.

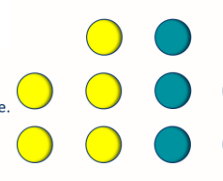

I can see 5 and 5

How do you see 10?

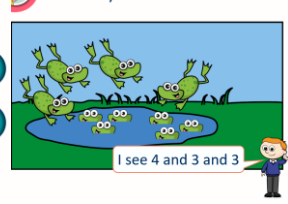

I see 4 and 3 and 3

Complete the stem sentences.



5 and 5 make 10
10 is made of 5 and 5

In PSHE, we will be comparing what we were like as babies to what we are like now. We will be looking at the changes we have made since then and thinking about what changes may still happen to us as we get older. We will be sharing our baby photos with the class and seeing if people can guess who is who and what has changed from then to now.

In science, we will be identifying what material is best for an umbrella. We will be thinking about the words 'waterproof' and 'absorbent' and conducting an experiment to find out what materials have these properties.

In art, we will be learning about the artist Sonia Boyce. She is a modern British artist who draws self-portraits with colourful backgrounds.

In RE, we will be exploring what Shabbat is. Jewish families have a special meal and spend time with loved ones to start Shabbat peacefully. They light candles to mark the start of Shabbat on Friday evening. They share bread called challah bread and drink grape juice or wine to celebrate.

In DT, we will be gathering ideas to design an appealing hand puppet. We will include a variety of features and colours, so that it can be enjoyed by a child in Reception.

In geography, we will be thinking about our new enquiry question; 'What is it like for a child living in Peru?'. We will be looking at where Peru is on a map in comparison to the United Kingdom.

Have a lovely week.

Mrs Smith, Miss Marcazzo, Mrs Vidal, Mrs Blackler and Mrs Miller



Year 2 Weekly Information w/b 19.1.26

<p style="text-align: center;">2W Non - Uniform Day</p> <p>2W have been awarded a Non - Uniform Day for the number of laps completed during the Golden Run.</p> <p style="text-align: center;">This will take place on Friday 30 January.</p>	<p style="text-align: center;">Science</p> <p>Thank you so much for all the seeds and bulbs that the children brought in last week; they were so useful. In science this week, we will be looking at what a plant needs to be healthy. If you have any small plants that are not looking healthy and are wilted or pale we would love to have a look at them! Please could they be sent into school; they can be returned too.</p> <p style="text-align: center;">Many thanks.</p>	<p style="text-align: center;">Reading</p> <p>Thank you for your ongoing support with reading at home. Please remind your children to make sure they change their books in the morning when they have finished reading their book.</p> <p>Also, please ensure your child has their One Minute Read booklet in school every Tuesday.</p> <p style="text-align: center;">Many thanks.</p>
---	---	--

In English this week, we will be continuing to learn about letters and how they are written. This week we will be learning how to add 'er' or 'est' to a word when comparing two things e.g. big, bigger, biggest or tall, taller, tallest. We will be learning how to write statement sentences ensuring to use the correct punctuation. At the end of the week we will be recalling all of the sentence types we have been learning about and writing an example of each.

In reading, we will be concluding our reading of the book 'The Dark' by Lemony Snicket. Our main focus this week is to think about how we can change our voices to convey the emotions of a character. We will then be reading out loud in order to practise expression.

The Spelling Shed assignment will be set on Tuesday and 5 Spelling Bee assignments are to be completed by the following Tuesday.

In Spelling Shed this week the children will be learning how to spell words where 'ed' is added to words ending in 'y'. e.g. copied, replied, spied, fried, applied etc.

This week's Spelling Quiz words are below. The Spelling Quiz will be completed on Tuesday in the Learning Journal.



For review:	come, here, school
Might be new:	busy, eye, poor
Can you do?	important, notice

This week in Fluency Bee – below you will find some examples of how we will be exploring comparison of numbers to 20.

w/b
19.1.26

Compare representations
Find the difference

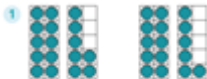
Tick the set which has more. Use $<$, $>$ or $=$ to complete the comparisons.

1  1 

2 

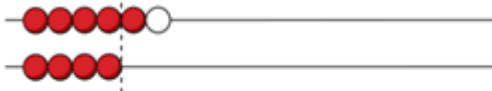

The difference between 6 and 4 is

w/b
26.1.26

Order numerals
Greater than or less than
Greater than or less than?

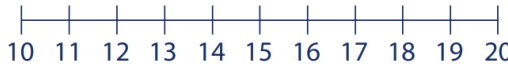

1 15 is _____ 17

Write the numbers in order from smallest to greatest.

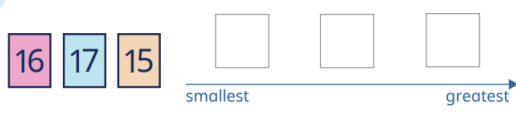
1 

In maths this week, we will be carrying on with our unit on money. We will be comparing amounts of money; making a pound; calculating with money and finding change.

In science this week, we will be thinking about what plants need to stay healthy. We will know that plants need: water to grow, the right temperature, light for healthy growth and that healthy plants have green leaves and strong stems.

In history this week, we will be looking at our first explorer, Christopher Columbus. We will be learning about his journeys across the sea and how they made a significant impact on the world.

In art this week, we will be starting our topic on artists that share ideas through sculpture. We will be looking at how clay can be moulded into different shapes by rolling, squeezing, pulling and pinching.

In PSHE we will be learning about how we change as we get older. We will be talking about how our bodies change, and what the children could do / will be able to do at each stage, from a baby up to an adult. We will be sorting objects and pictures on a timeline.

Class Assemblies

Last week the children brought home their lines to learn for their Class Assemblies – please support them with learning these so that they can say them loudly, clearly and with expression. Below are also the links for the songs if they wish to practise these at home:

Continents

<https://www.youtube.com/watch?v=KiXjGFOzY3c>

Oceans

<https://www.youtube.com/watch?v=X6BE4VcYngQ>

1666

<https://www.youtube.com/watch?v=J5eVIKWSHAA>

(including learning the sign language)

Thank you as always for your continued support.

Mrs Jayasuriya, Mr Martin and Mrs Williams
Y2 Class Teachers



Year 3 Weekly Information w/b 19.1.26

3W Reward

As a class reward, 3W may bring a small cuddly toy to school on Tuesday 27.1.26

Year 3 Class Assemblies

We hope to see as many of you as possible at our Class Assemblies this week:

3W: Tuesday 20.1.26
3L: Wednesday 21.1.26
3WH: Thursday 22.1.26

A big thank you for helping with learning lines.

One Minute Read

This week, our One Minute Read is the third text in the Spring booklet 'Kings and Queens of England': King John.

In English this week, we are continuing to learn about persuasive devices. We'll be learning about point/evidence/explain and also repetition. We will recap on the persuasive devices we learnt about last week and will use them in our independent writing.

Here are this week's spelling quiz words (for the quiz on 27.1.26). We would appreciate it if you could please help your child to practise them at home.

For review:	great, would
Might be new:	women, ordinary, actual
Can you do?	accident, favourite, suppose

In maths this week, we are going to be reminding ourselves about the 10 times table. We are then going to examine how we can use multiplying by 10 to help solve more complex calculations. For example, if we know $3 \times 4 = 12$, then what is 3×40 ? What about 30×4 or $120 \div 3$? We will continue to refine our ability to explain our understanding of mathematical concepts through our diving deeper activities. Children accurately completing all their tasks in a lesson will be able to choose a White Rose Maths 'Fast Finishers' card. Here's an example of a card available this week:

5 Naomi and Rafi are collecting stickers.



Rafi collects three stickers on Monday.
He collects twice this amount on Tuesday.
He collects two stickers on Wednesday.
Naomi has eight times as many stickers than Rafi.

a. How many stickers does Naomi have?
b. How many more stickers does Naomi have than Rafi?

6 What are the missing numbers?

a. $60 \div 3 = \square$ $20 \times 3 = \square$ $60 \div 20 = \square$ $3 \times 20 = \square$

b. $200 \div 4 = \square$
 $\square \times 4 = 200$
 $200 \div \square = 4$
 $4 \times 50 = \square$

c. $\square \times 8 = 24$
 $\square \times 80 = 240$
 $240 \div \square = 80$
 $240 \div \square = 30$

Fast Finishers Maths: Problem-solving, Ages 7-8 © 2022 White Rose Education Services Ltd / Scholastic

Coming up soon in our speedy maths sessions:

w/b 19.1.26	Know 2x, 3x, 4x, 5x, 8x, 10x tables at speed Add and subtract two tens at speed. Know 10 more and 10 less than 3-digit numbers.
w/b 26.1.26	Know division facts for 3x table facts at speed. Know 10 more and 10 less than 3-digit numbers. Add and subtract 1-digit and 2-digit numbers. Know 2x, 3x, 4x, 5x, 8x and 10x tables.

For the wider curriculum, in science we will be focusing on the role of the stem to transport water and nutrients and how it supports the plant.

In DT, we will be learning how computers can help us when designing. In geography we will be learning about counties.

In PE, we will be continuing to develop our tag rugby skills by focusing on defending safely by taking an attacker's tag.

We are continuing the Changing Me puzzle piece in PSHE. This week, we will discuss the meaning of stereotypes and what that means in our family settings. We will discuss how this can be or look different in families depending on our family set up.

Is your child (or yourself) anxious about the Golden Hinde residential trip?

Here's some steps you can take starting now to get them ready for a fun trip. Don't leave it all to the last minute, especially staying away from home. Doing activities plenty in advance allows you the chance to take small steps and try something again if it doesn't go to plan first time around.

You know your child best, so adapt their preparation to how much (or little) they need in advance.

They're worried about staying away from home...
Maybe they've already been to the Year 2 sleepover last year.
Try play dates that extend to getting ready for bed and a late film. This replicates the Year 2 Sleepover and helps build confidence with getting changed before bed on the Golden Hinde.
Spend a night away from home at a relative's house. You could turn this into two steps by staying yourself for the first time.
Spend a night away from home at a friend's house.
You could have a night sleeping on roll mats and in sleeping bags, too (in their room, downstairs at home, at a friend's house), if they're worried about not having a bed to sleep in.

They're worried about it being a big trip...
Have a local day trip together that involves some walking and visiting somewhere new.
Look at some pictures of the Golden Hinde on the internet.
Have a day trip to London together – you could even find the Golden Hinde and see the area around it.

Golden Rules...

- Keep opportunities for discussion open so they know they can talk to you.
- Talk about the trip positively yourself. If you tell them or show them that you're worried, they'll pick up on that and please don't promise they can go home during the trip. We will always call you if needed but once that seed has been planted they won't forget.
- Emphasise all the fun they're going to have and what a great opportunity it is. So many people have never slept on a ship and they get to do it!
- Don't write them notes to look at on the trip. You can tell them you missed them and give them a big hug when they get back.
- Pack for the trip together. They'll know what they've got with them and how to fit it all back in their bag at home time.
- Talk to your child's class teacher about any concerns. We're very experienced with this trip and other residentials and are ready to support your child to have a great time away.

We'll be preparing them at school, too, by talking about what we will do on the trip, looking at photos, discussing how we can all support each other and answering as many of their questions as possible in the lead up. All the staff are already looking forward to a great adventure together, and at a later date we will let you know who is going on the trip.

Have a great week,

Mrs Hill, Mr Loughlin, Mrs Waldron and Miss Wood
Y3 Class Teachers



Year 4 Weekly Information w/b 19.1.26

Class Assemblies

Thank you so much for coming to watch children in their Class Assemblies.

We are so proud of how hard they worked on them.

Water bottles

Please ensure your child has a plastic water bottle with a sports cap with them at school each day.

Equipment

Just a reminder that all equipment the children need during the school day is provided for them. They do not need to bring in anything from home.

In English, the children will continue learning the knowledge and skills needed to write their own diary entries. These include writing with fronted adverbials, using the first person and conveying emotion. We will apply these to our writing throughout the week.

In reading, we will continue to explore our class text *The Iron Man*. We will be reading ahead in the story, discussing key events and characters, and developing our vocabulary while responding thoughtfully to the themes and ideas in the book.

For review:	exercise, imagine, length
Might be new:	enough, possession, reign
Can you do:	category, environment

In maths this week, we will be continuing to build on our learning across the curriculum. We will be using related number facts and informal written methods to help us multiply a two-digit number by a one-digit number, focusing on accuracy and efficiency.

Please can you support your child with completing Times Table Rock Stars each night. It is also important the children complete a soundcheck at least once a week so we can track areas the children need support in.

Coming up in speedy maths (*indicates new learning):

w/b 19.1.26	*Know simple equivalent fractions Know all tables mixed at speed. Know pairs of numbers to 100. Continue simple number patterns
w/b 26.1.26	*Know pairs of tens to 180 Know simple equivalent fractions. Know all tables mixed at speed. Know simple equivalent fractions Add and subtract pairs of 2-digit numbers at speed.

In science this week, children will look at ways that scientists classify animals and will explore some of the related vocabulary.

In PSHE, the children will be having a visit from local Epsom and Ewell police officers. They will be talking to the children about the job and what they can do to keep themselves safe.

We will also be teaching the children about what happens to a girl's body as they grow up. We will be discussing the stages of the menstrual cycle.

In art, we will be re-visiting the techniques of hatching and cross-hatching. We will spend this week's lesson learning about Vincent Van Gogh and his incredible art pieces. We will also have the opportunity to sketch some of his designs.

In computing, children will consider search engines. Why do they generate the results that come up?

In history, children will consider how World War Two started. Why did the German people support Adolf Hitler?

Have a great week.

Miss Croucher, Mr Vidal and Mrs Beadle
Y4 Class Teachers



Year 5 Weekly Information w/b 19.1.26

Golden Books

Golden Books will be sent home this week. We hope you enjoy looking at your child's work

After you have written a message on the sticker in the book, please ensure it is returned to school for safekeeping.

All Golden Books should be sent back to school by the end of next week, please.

O2 Young Voices

We are all so excited for Young Voices this Thursday, 22.1.26.

Please remember that children should bring a packed tea to eat at the O2 arena, their water bottle and usual school uniform should be worn. No sweets please.

If you have ordered a YV T-shirt, we will give these out at school on the day, otherwise they should bring a plain white t-shirt to wear.

Please see the [letter](#) for further details. It's set to be a night to remember!

Class Assemblies

Advanced notice: The children are very excited to perform their Class Assemblies to you next week. The doors will open to parents at 8.45am and assemblies will start at 9.00am.

Wednesday 28.1.26 – 5T
Thursday 29.1.26 – 5P
Friday 30.1.26 – 5J

Your child's books will be available for you to look at in the Hall.

We look forward to seeing you there!

In English and reading this week, we will be revising how we can use fronted adverbials in our writing and looking at including parenthesis in our work. We will also be focusing on speaking and performance as we start to write our Class Assembly and act from a play script. We will be using role play to perform a version of Shakespeare's play Rome and Juliet, using inference to interpret the meaning of the play.

This week in class and on Spelling Shed we will look at words with suffixes where the base word ends in -fer. Our next One-Minute Read from tomorrow (and due next Tuesday 27.1.26) is **Real Life Mysteries 3**.

Thank you for your continuing support with your child's homework.

The children will be having a spelling quiz on Tuesday 27.1.26 on these words:

For review:	enough, separate, through
Might be new:	develop, forty, muscle
Can you do?	explanation, unfortunately

In mathematics, pupils will be building on the knowledge and skills developed over the previous weeks to solve problems involving multiplication and division.

We will also be revisiting fractions, with a particular focus on multiplying both unit and non-unit fractions by an integer. We will be using bar models to help support our learning.

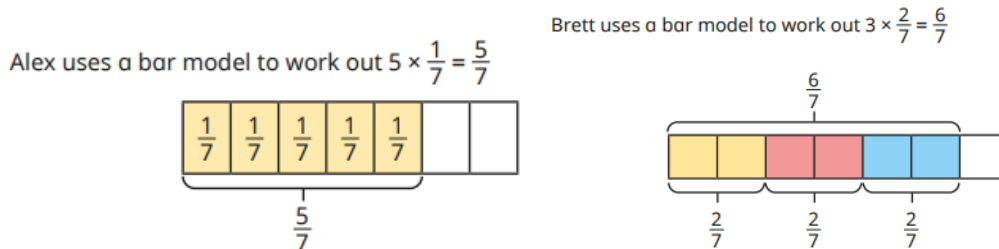

Our speedy maths will be:

w.b: 19.1.26	Use times tables to work out related multiplication and division questions Know all times tables to 12 x 12 including division facts at speed Subtract 2-digit from 3-digit numbers Convert l to ml and vice versa
w.b: 23.1.26	Know pairs to 1,000 Add pennies and pounds Subtract 2-digit numbers from a 3-digit numbers Convert m to km and vice versa Continue simple number patterns

In DT this week, we will be finding out how market research can help us to design a product that consumers will enjoy.

In geography, we will continue to look at climate change, focusing on the primary causes of climate change (including natural factors and human activities such as burning fossil fuels, deforestation).

Next week in science, we will think about how a boy's body changes during puberty. This will link with our PSHE topic of 'Changing Me'. The children will learn that puberty is a natural process that happens to everybody. Here are some of the resources we will be looking at in class:

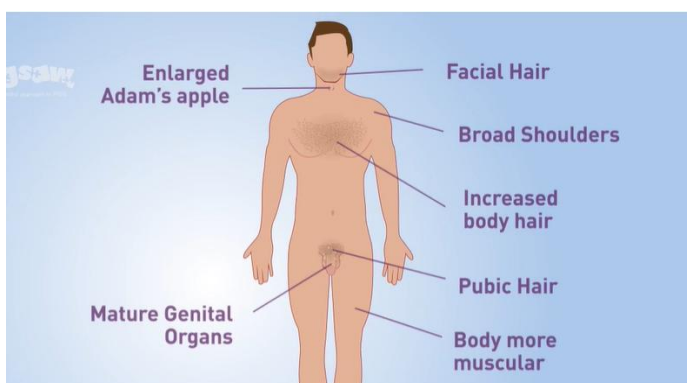

A reminder that in two weeks' time (w/b 2.2.26), we will be learning about conception. This will be done in an age-appropriate and sensitive way as mentioned at the Welcome meeting in July. The following slides will be shared:

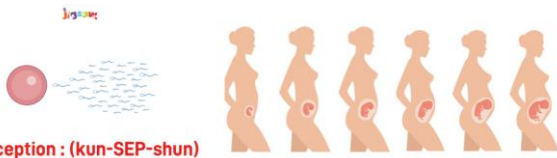

Conception : (kun-SEP-shun)

Resources and key vocabulary used in this lesson

- conception
- sexual intercourse
- fallopian tube
- embryos
- IVF
- contraception
- Fertilisation
- cervix
- pregnancy

the sperm would travel up through the cervix

You have the option to withdraw your child from the part of our PSHE lesson where we will discuss consent and alternative methods of conception such as IVF.

Have a wonderful week,

Miss Jenkins, Miss Penn and Mrs Temlett
Y5 Class Teachers



Year 6 Weekly Information w/b 19.1.26

Football fixtures

Here is a reminder of the upcoming Epsom and Ewell schools football league fixtures:

19.1.26 – Boys v Epsom Primary (home)
26.1.26 Girls v St Clements (home)

There is also a football tournament for boys and girls on Thursday 29 January more details to follow.

Practice National Curriculum Tests (NCTs)

In order to help prepare the children for the NCTs in May, we will be holding practice tests on 26/27 January and 2/3 February. The primary aim of doing this is for the children to understand the processes involved, so it is less daunting in the summer. This has been well-received by the children in the past. More details will follow in due course.

PE kits

Last week, six children in Year 6 did not have their PE kits. Please may we remind you that our PE and Games lessons take place on Friday afternoons, and that all children need to wear a full kit: a PE t-shirt, shorts and/or tracksuit bottoms, a fleece and suitable trainers.

In English this week, we will be continuing to develop our grammar and punctuation skills. We will investigate synonyms and antonyms, regular and irregular verbs, verb tenses and the active and passive voice. Examples of active and passive sentences are:

Active: The ball smashed the glass in the greenhouse.
Passive: The glass in the greenhouse was smashed by the ball.

Our maths learning this week will include how to solve proportion problems, how to add and subtract decimals and how to multiply and divide by integers.

These are the words for the Spelling Quiz on Tuesday 27 January. Please take time to practise these with your child:

For review:	correspond, equipment, immediately
Might be new:	nuisance, rhythm, sincerely
Can you do?	definitely, existence

In science, we will be investigating genetics and inheritance and why living things produce offspring that are like them but not identical.

In history, we will start our new topic learning about the ancient Mayan people. We will begin with finding out who they were and where they lived.

In PSHE, we be covering 'Babies: conception to birth' as part of the 'Changing Me' topic.

In art, we will continue to take inspiration from street artist Jean-Michel Basquiat. We will consider how we can use colours and shapes to make a statement in our paintings.

Have a great week,

Mrs Bowe, Mr Gordon and Ms James
Y6 Class Teachers